

EMOTION

by Moritz Leicht



Zu meiner Person

Betreiber von smart EMOTION



Moritz Leicht

Projektmanagement Ladeinfrastruktur
Elektrisch seit 10 Jahren

smart EMOTION

Fachportal rund um smart
Artikel
Forum
Wiki
Austausch mit smart

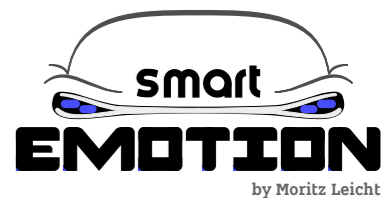

Die Historie von smart

Von 1969 bis 2020

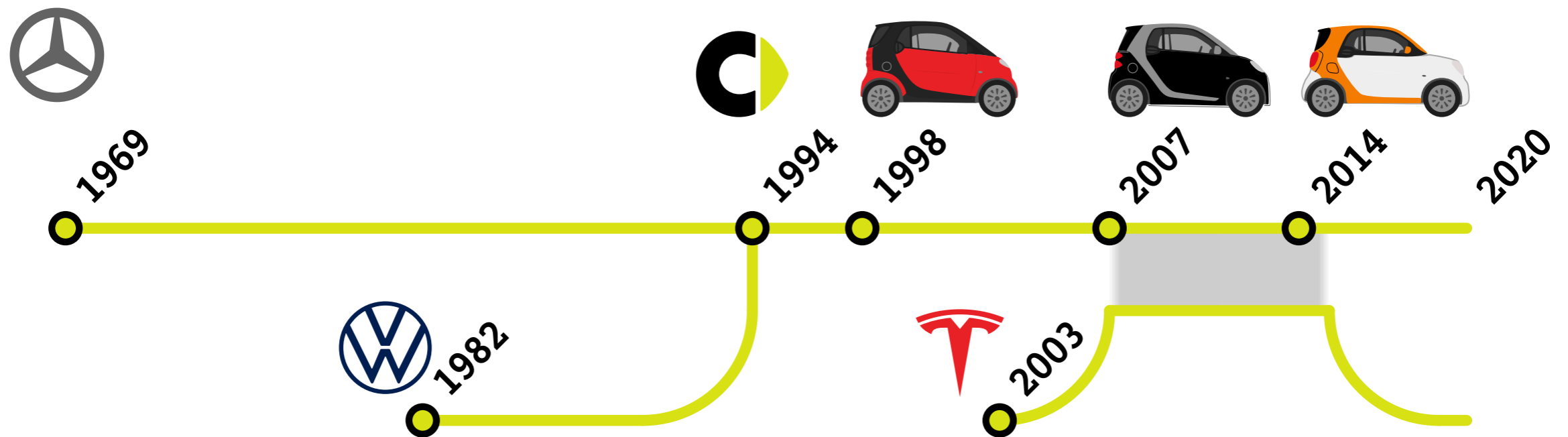

Prof. Johann Tomforde

2017

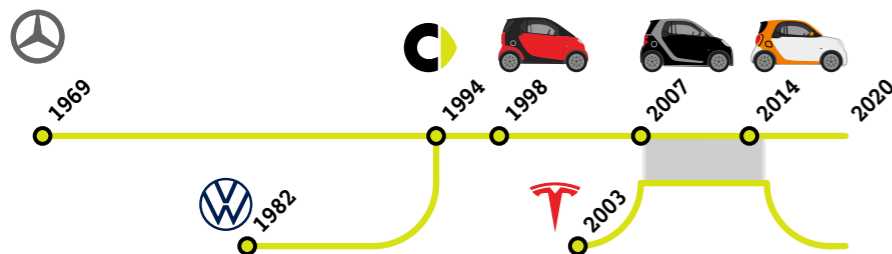

Stadtauto als Diplomarbeit

1969

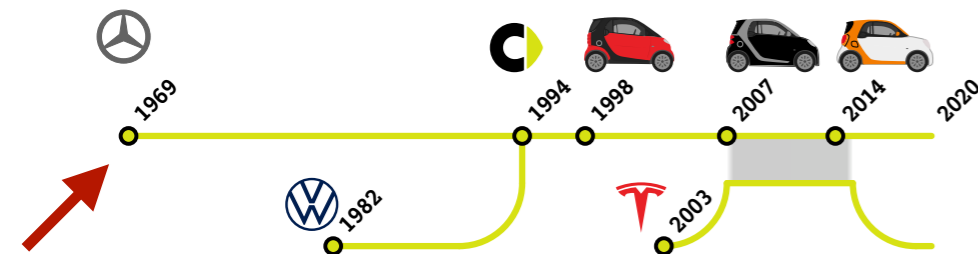
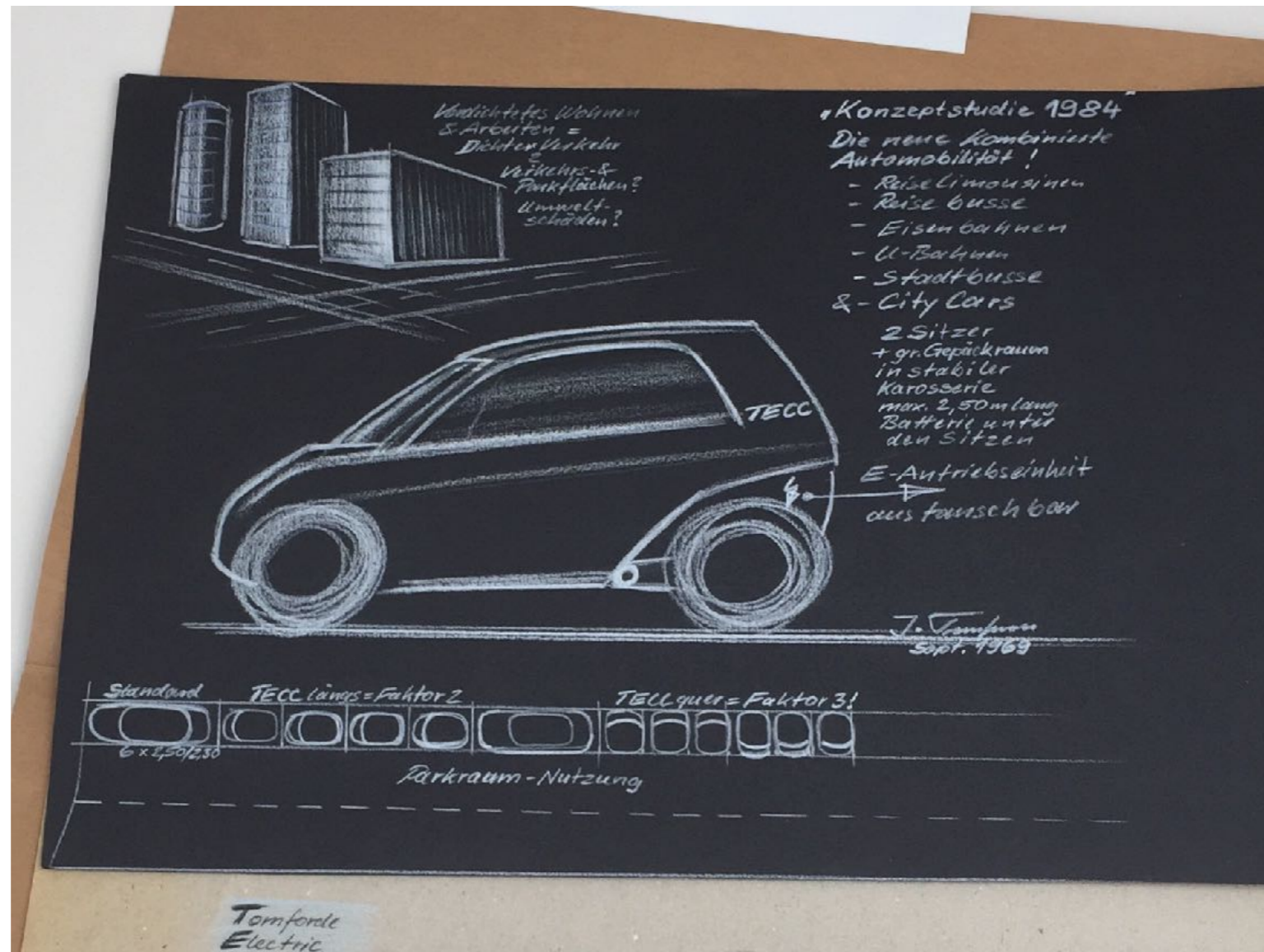

Natürlich vollelektrisch

1969

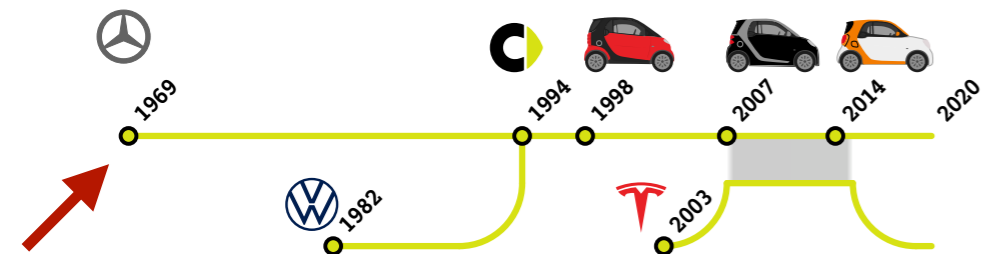
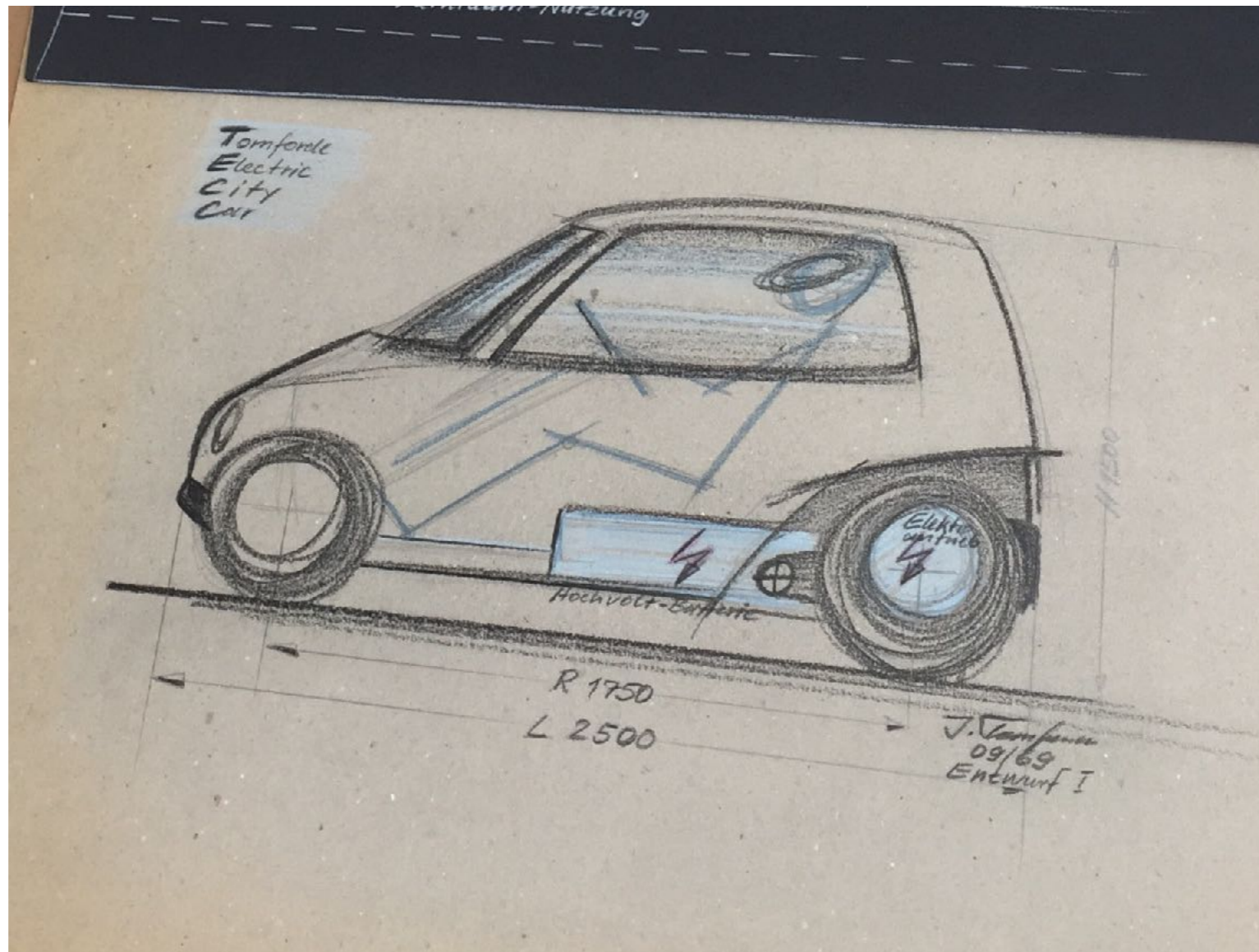

Mercedes Konzept

1972

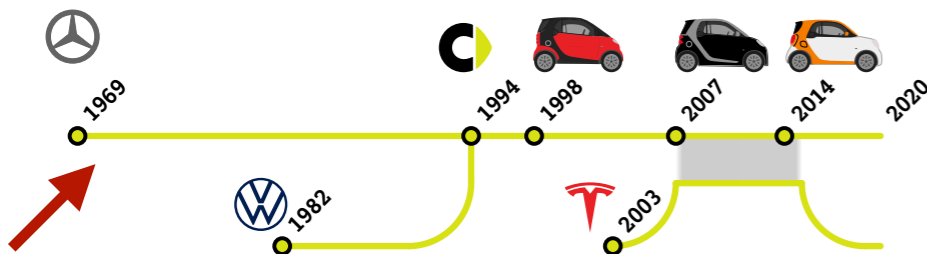
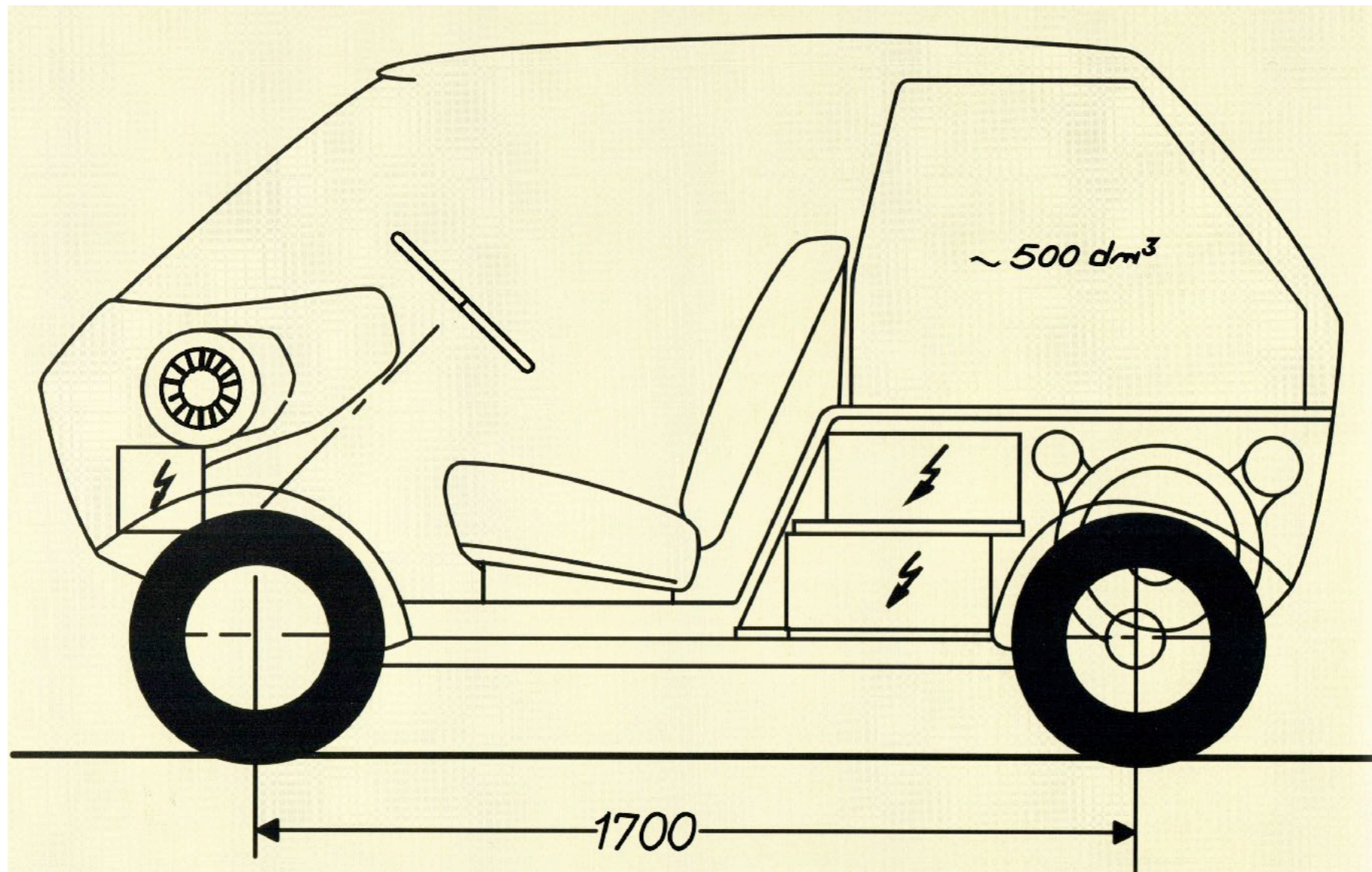

"Nahverkehrsfahrzeug" (NAFA)

1981 - 1985

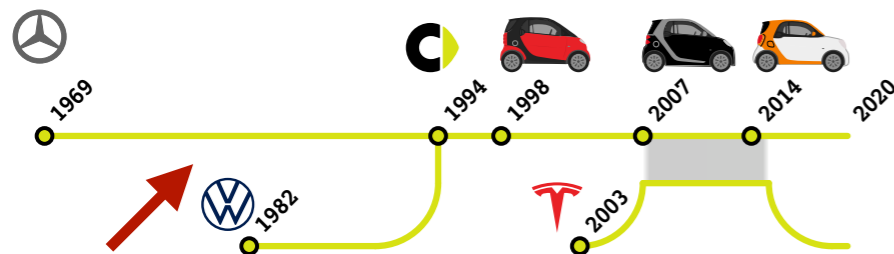

"Nahverkehrsfahrzeug" (NAFA)

1981 - 1985

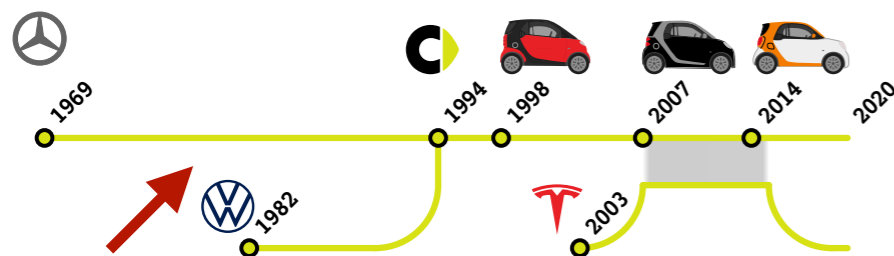

Dann auch elektrisch

1988

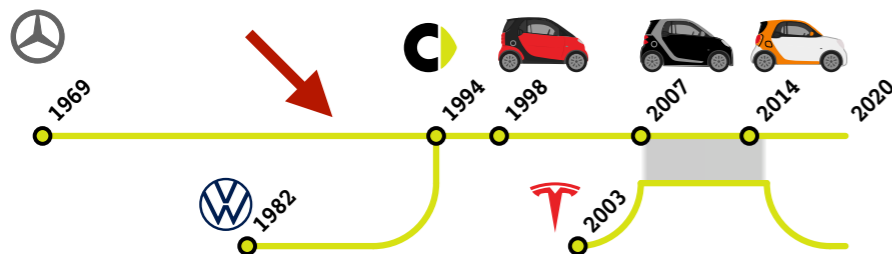

Druck von Außen

1991

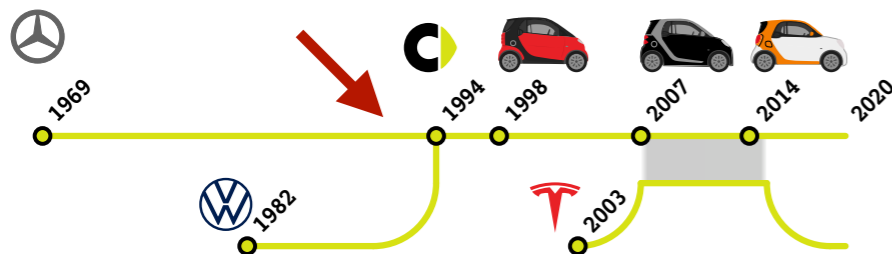
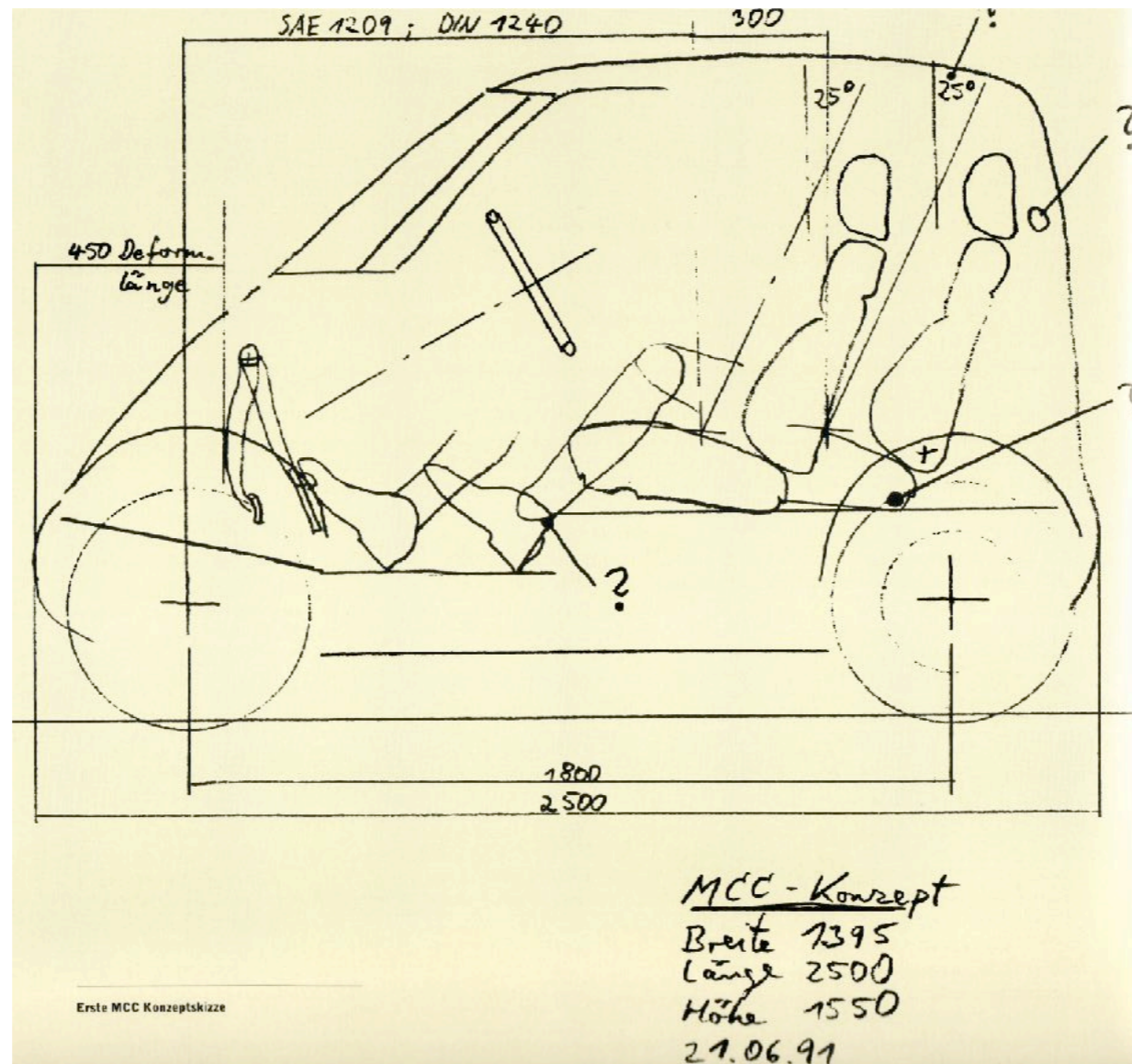

Nicolas Hayek

1982

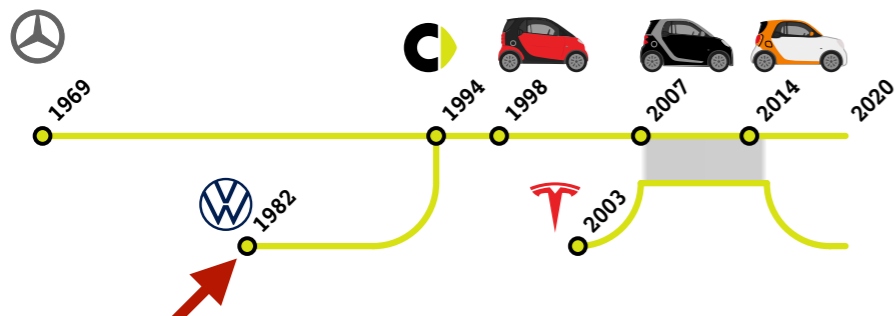

Konzeptauto alleine

Etwa 1985

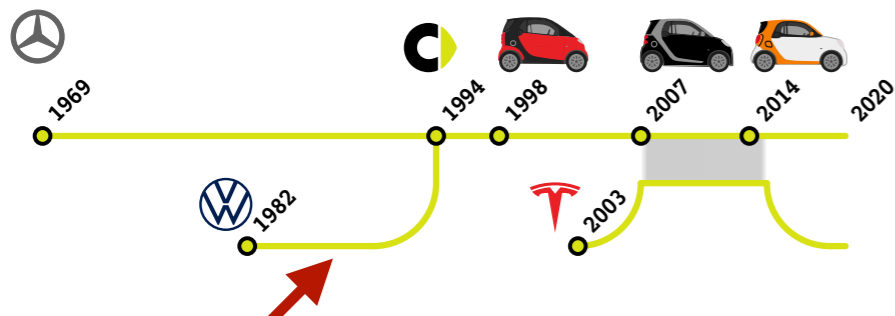

Swatch & Volkswagen

Etwa 1988

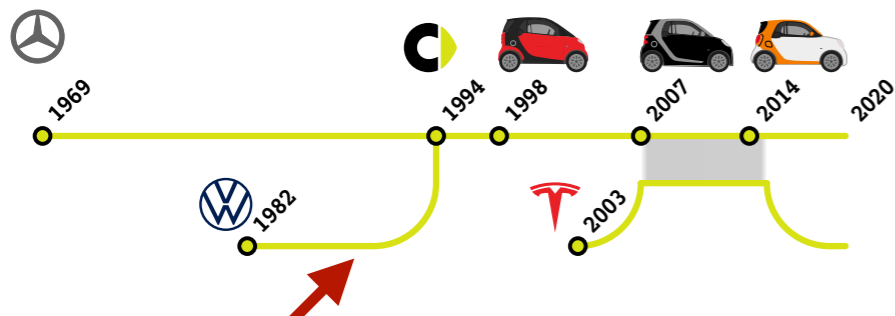

Mit Dr. Piëch das Ende

Etwa 1993

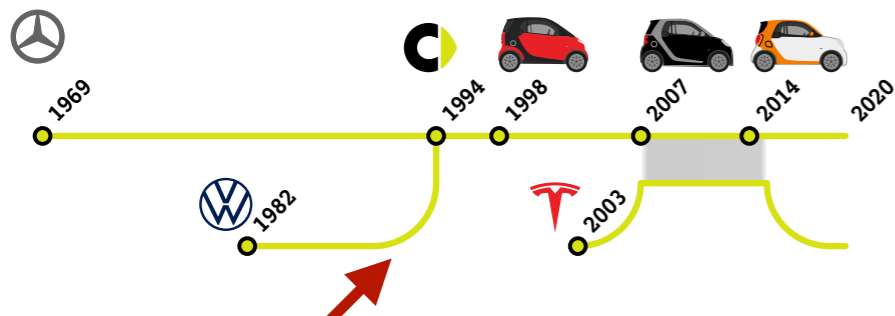

swatch und Mercedes

1994

smart

swatch **Mercedes** art

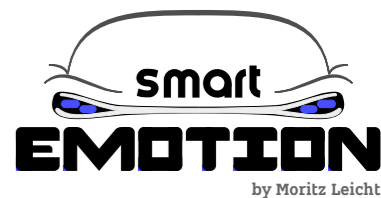
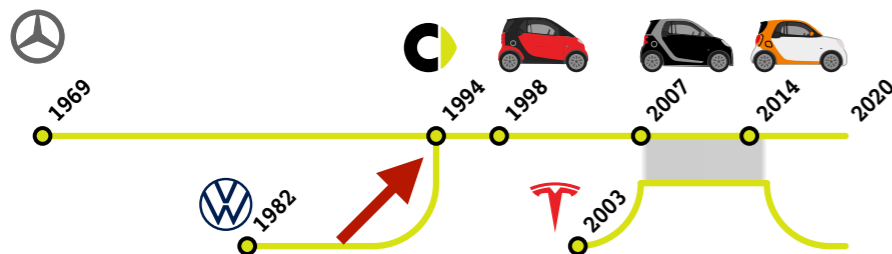

eco-sprinter

1994

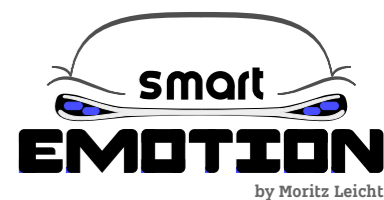
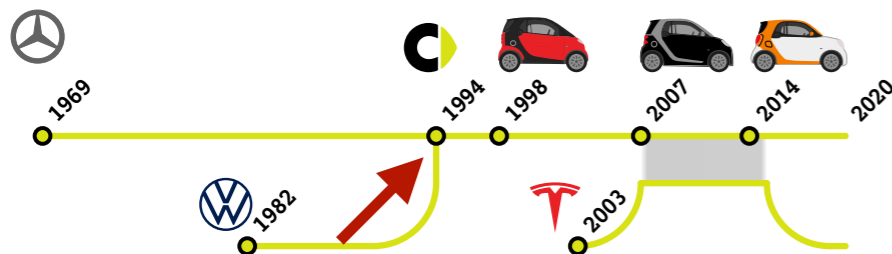

Swatch Car Concept by Mercedes-Benz

1995

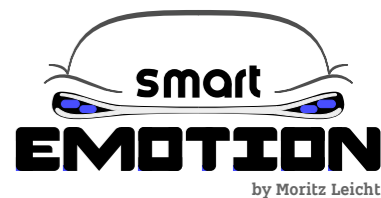
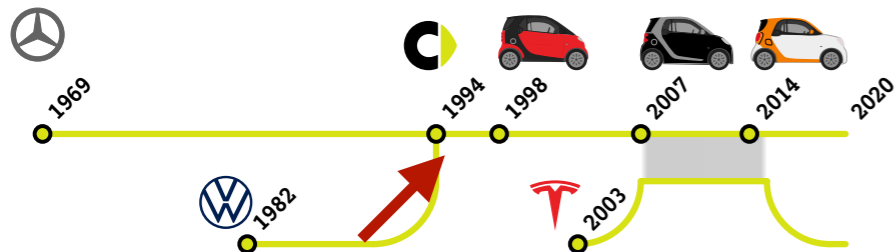

Spatenstich in Hambach

1995

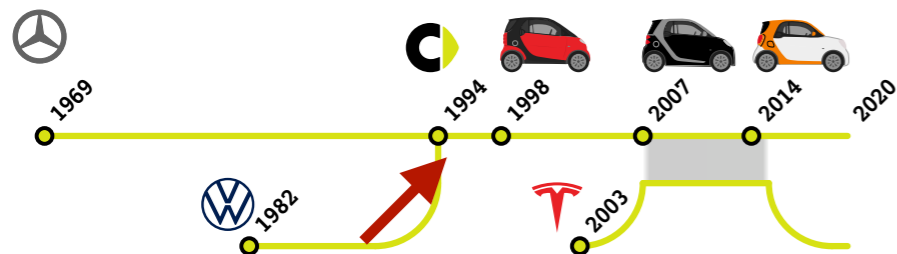

Smart Modular Concept

1996

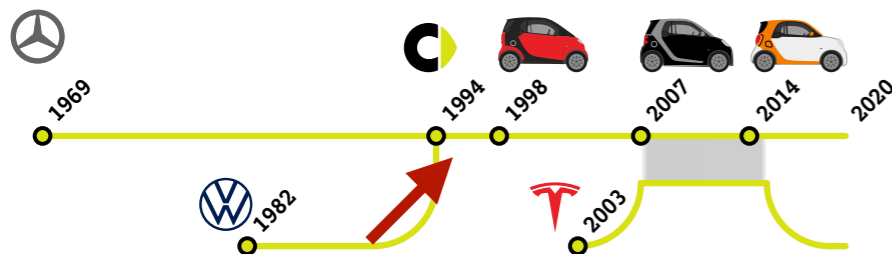

Nur Benzinmotor

etwa 1996

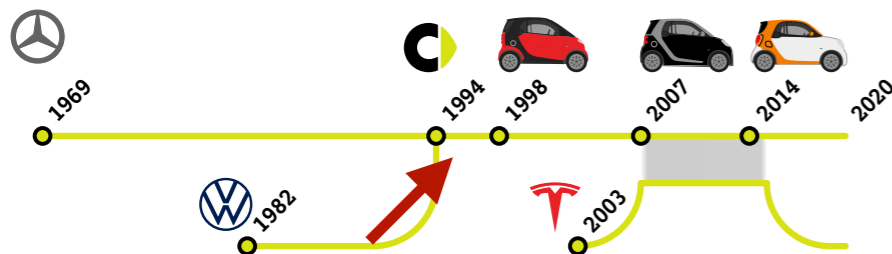

Fertigstellung smart ville

1997

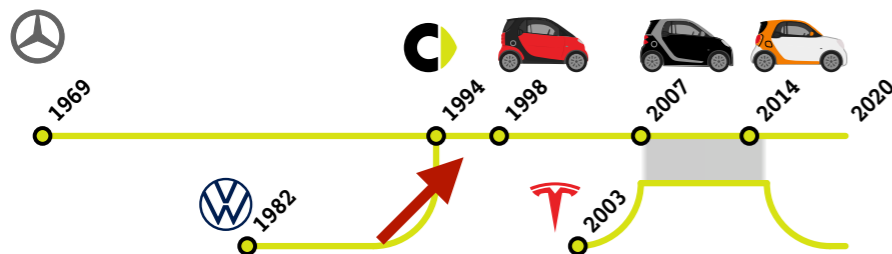
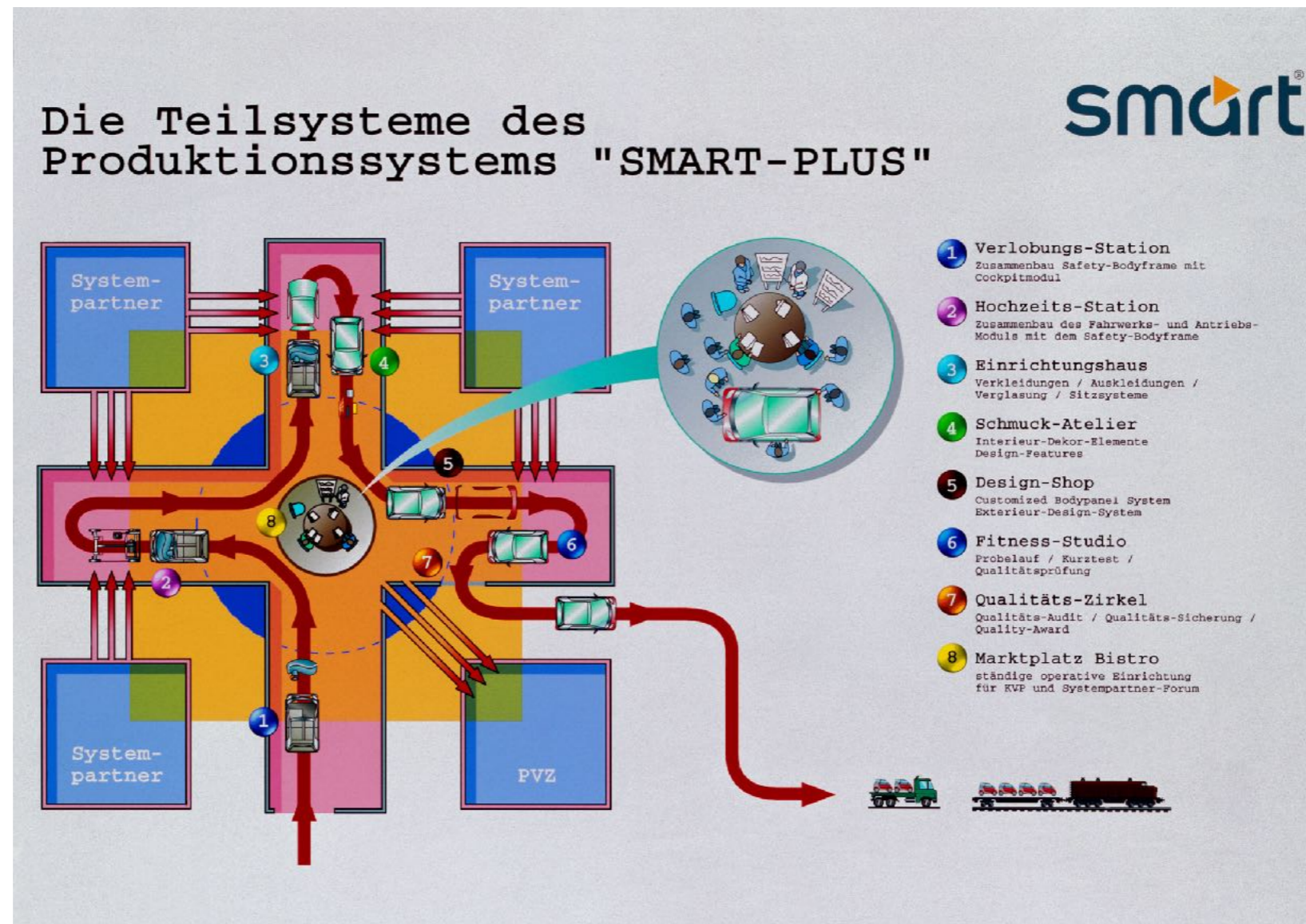

Weltpremiere des MCC auf der IAA

1997

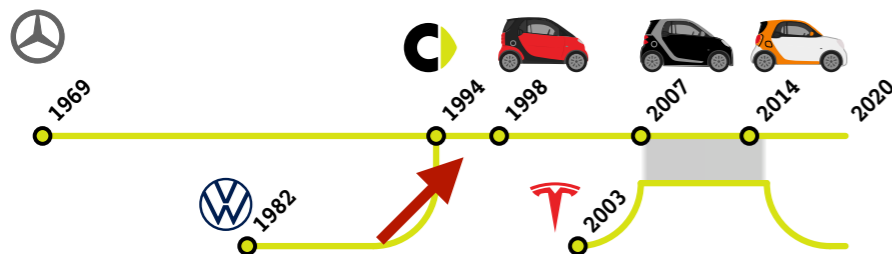

Sicherheit wie in der E-Klasse

1997

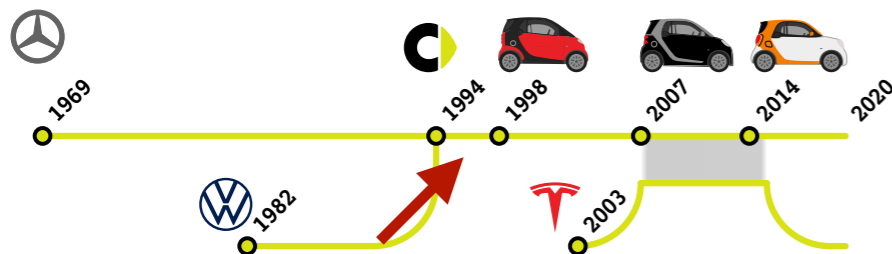
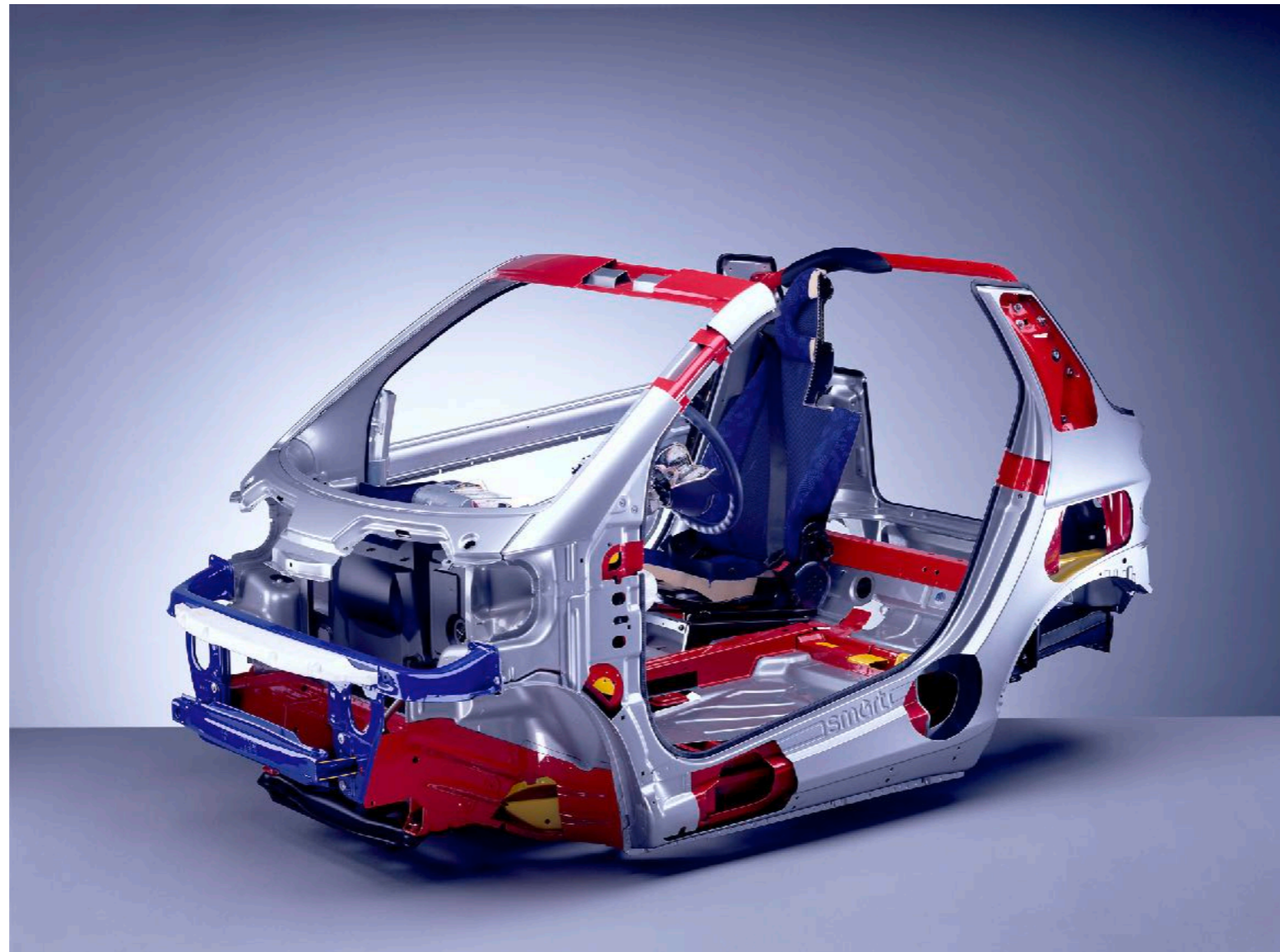

Ladesäule, statt Zapfsäule in der Serie

1997

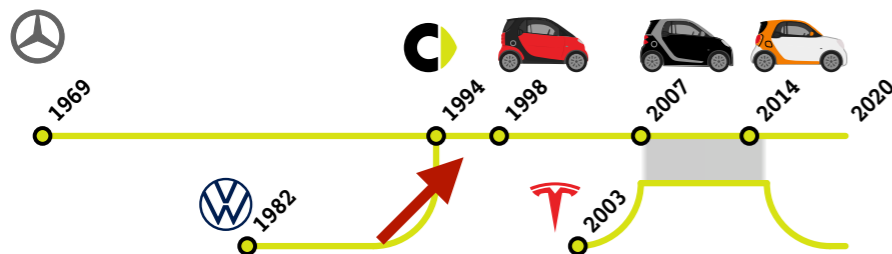
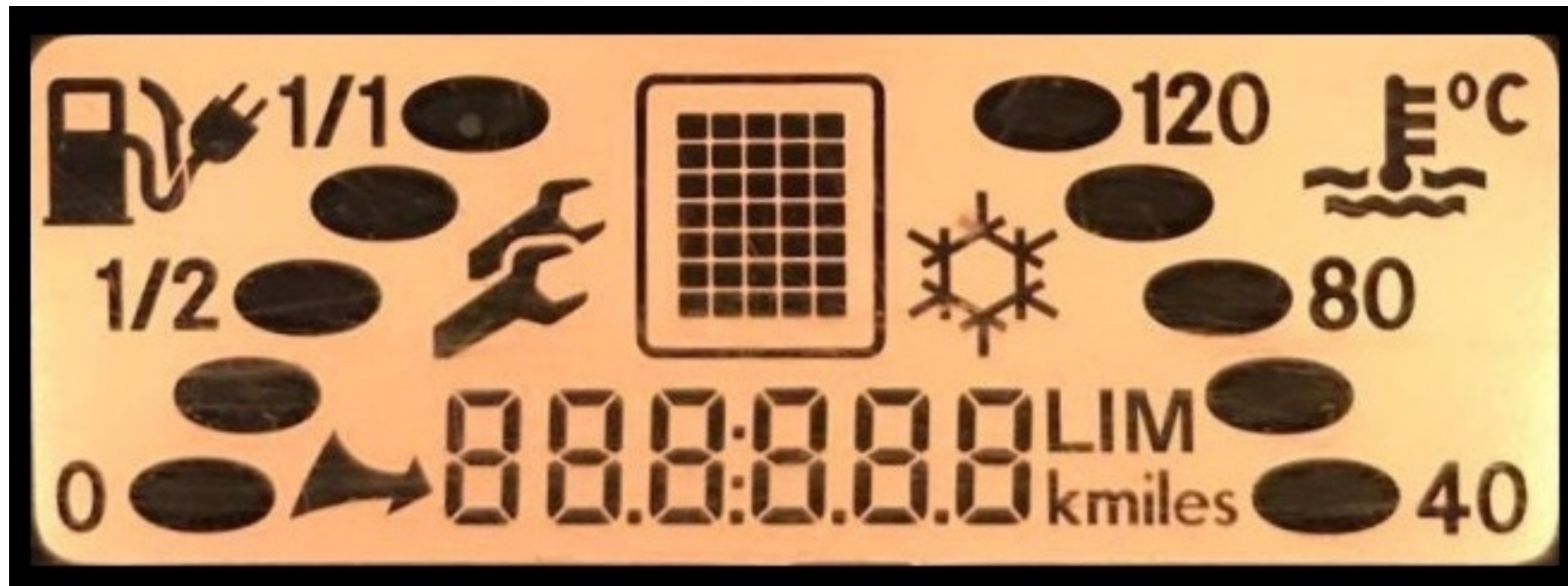

Swatch Uhr zum Produktionsstart

1997

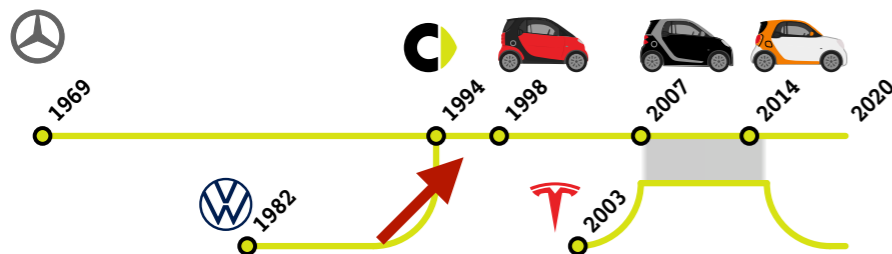

Elchtest gilt auch für den smart

1997

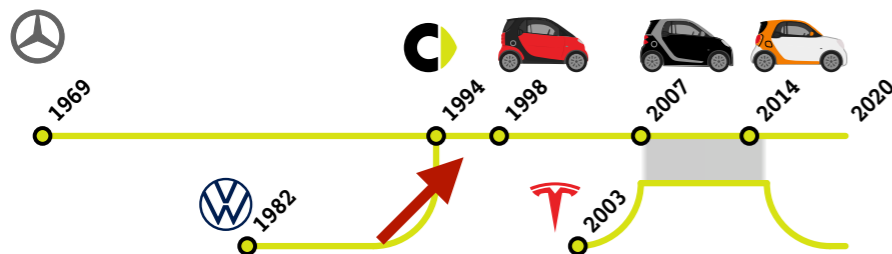

Verkaufsstart im smart center

1998

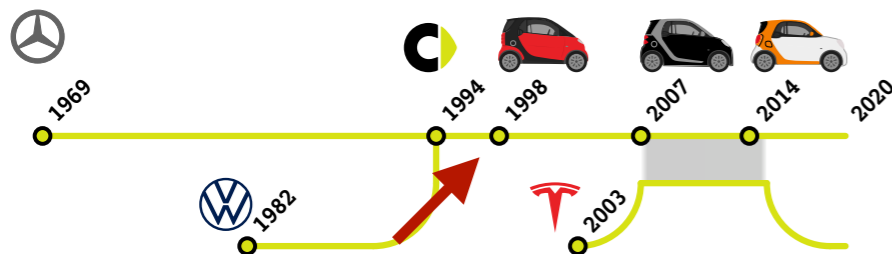

Innovative Park- und Werbemaßnahme

1998

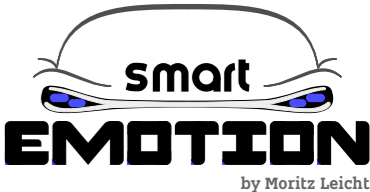
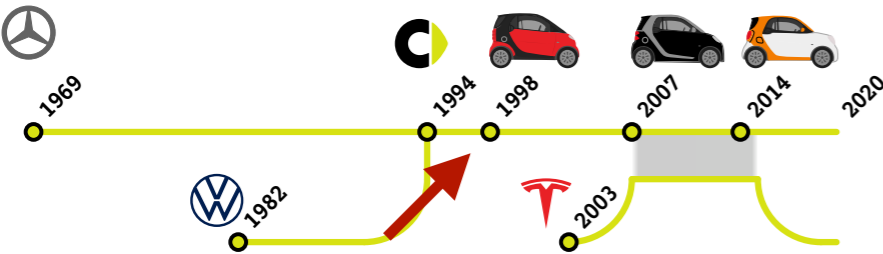

Cabrio war Pflicht

2000

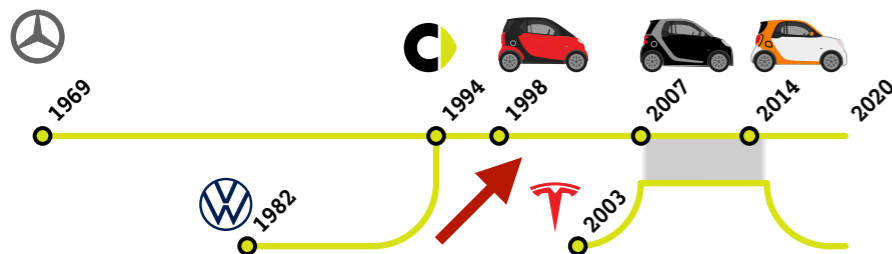

Weitere Modelle - fortwo

2002

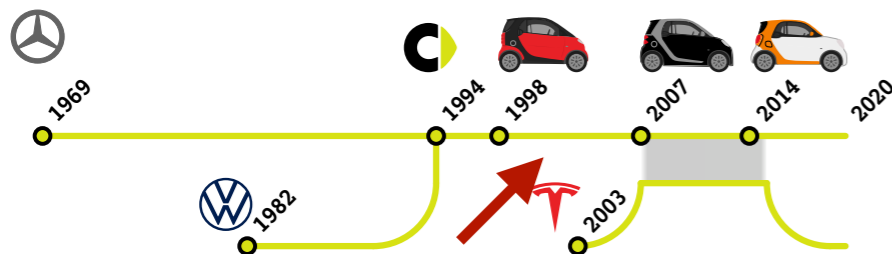

Smart SUV Studie - formore

2004

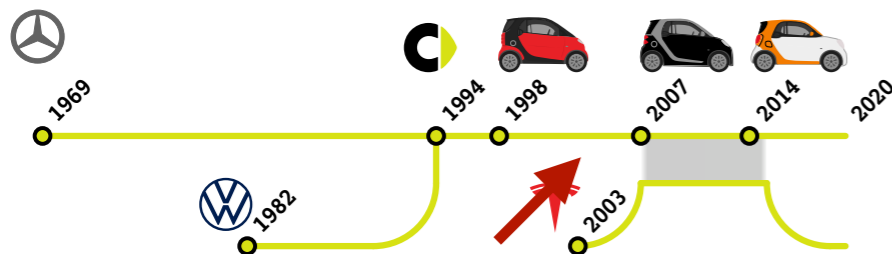

Zurück zu den Wurzeln - fortwo ED

2007

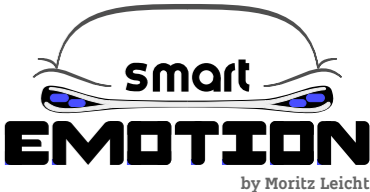
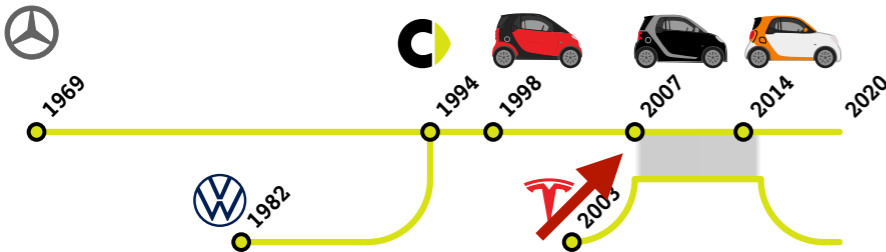

Smart electric drive by Tesla

etwa 2008

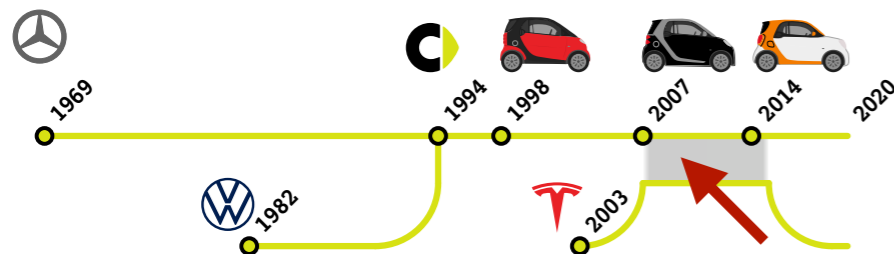

Tesla Roadster unter der Haube

etwa 2008

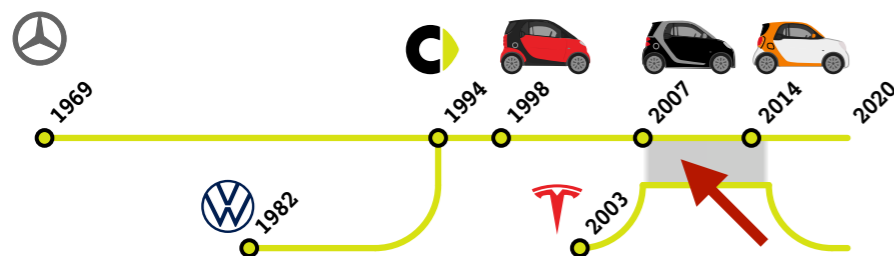

Tesla smart fortwo geht in Serie

2009

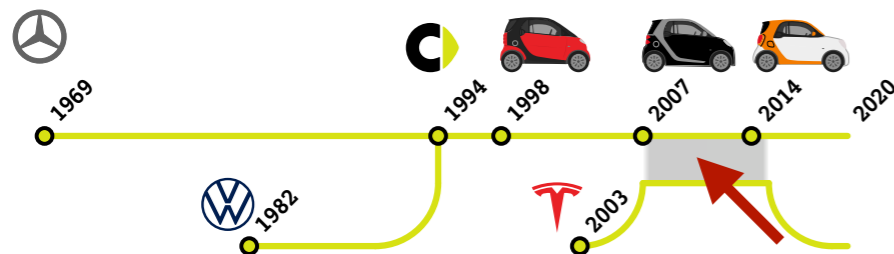

Eigenentwickelter smart electric drive

2013

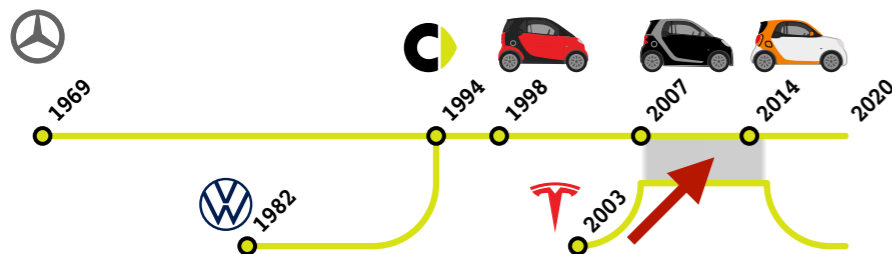

Verwechslungsgefahr !

2009 - 2013

smart ED 3. Generation

2012 bis 2016

Batterie: 17,6 kWh von Accumotive (Daimler)
Ladegerät: 3,6 kW / 22 kW von Lear / Brusa
Motor: 55 kW (80kW) von Bosch

smart ED 2. Generation

2009 bis 2012

16,6 kWh von Tesla
 2,8 kW von Tesla
 30 kW von ZYTEK

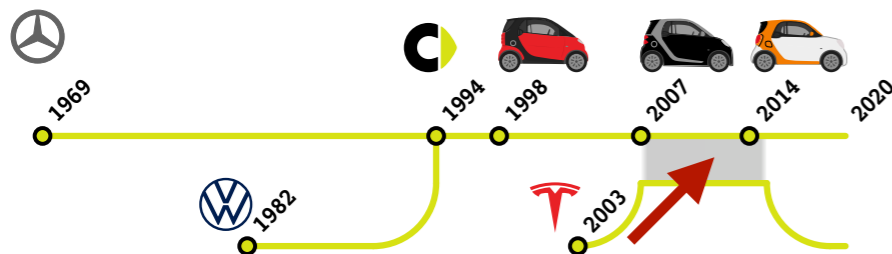
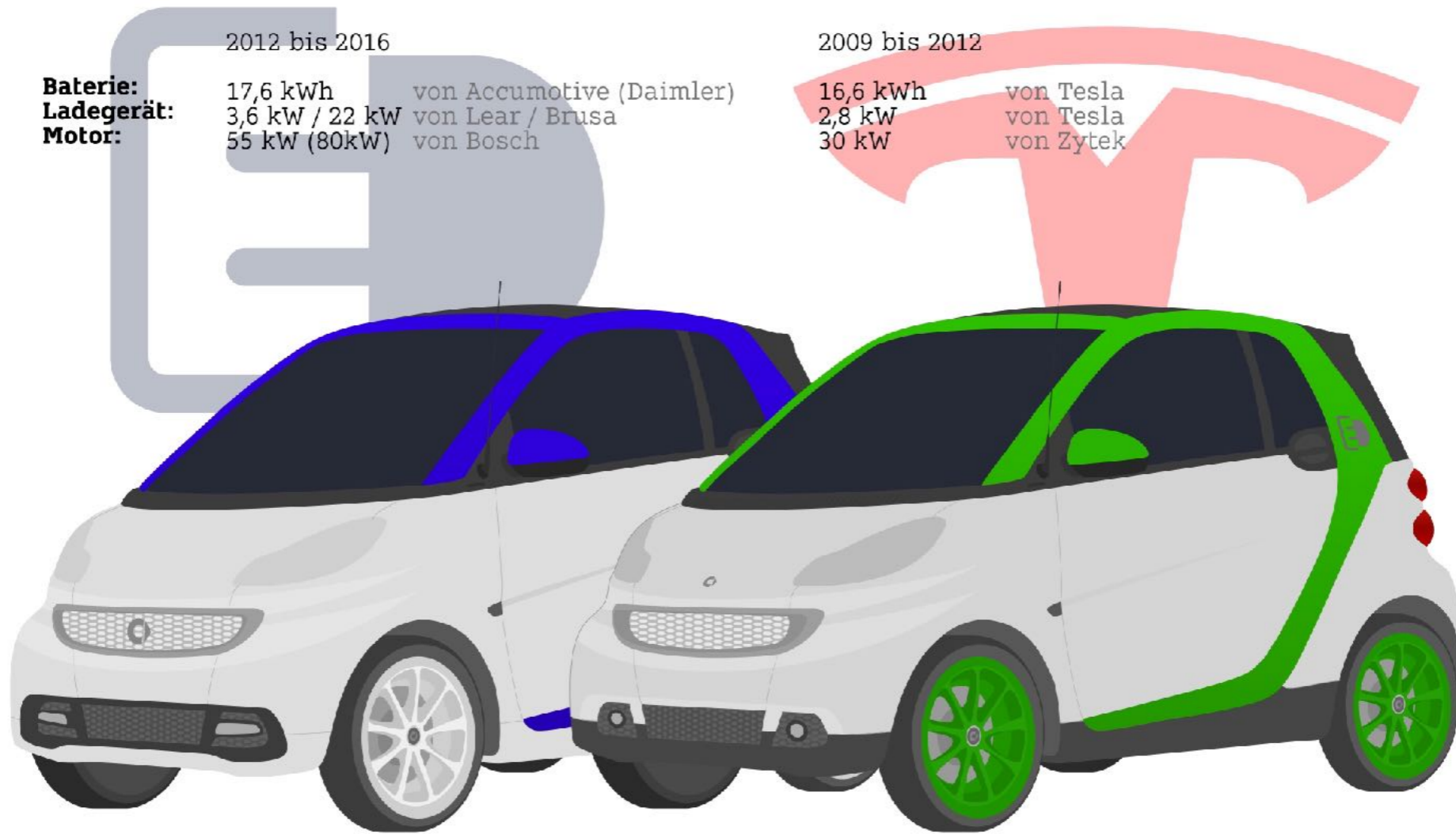

Smart electric drive als BRABUS

2013

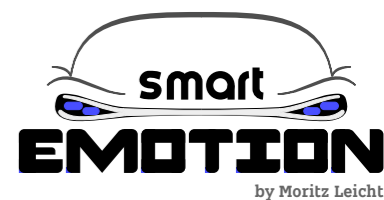
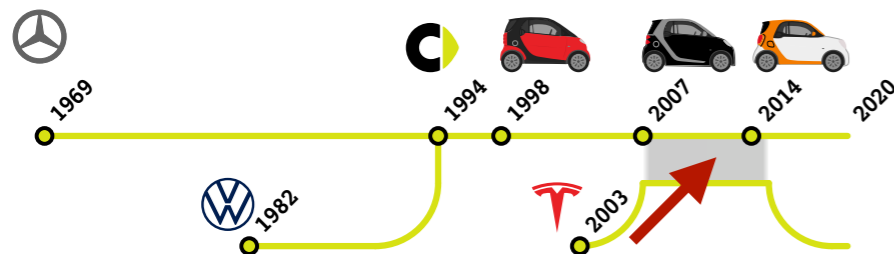

Vierte Generation electric drive

2017

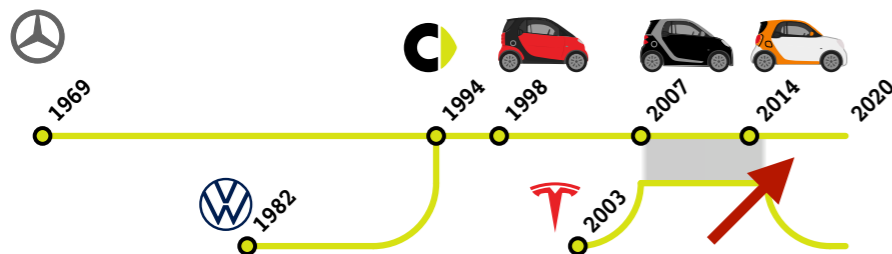

Smart wird vollelektrisch - aus ED wird EQ

2018

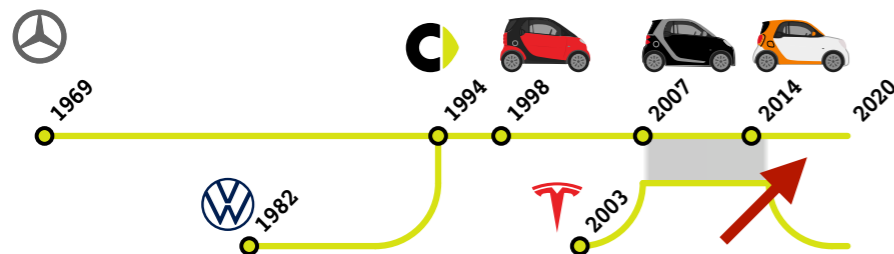

Der neueste smart ist ein SUV

2023

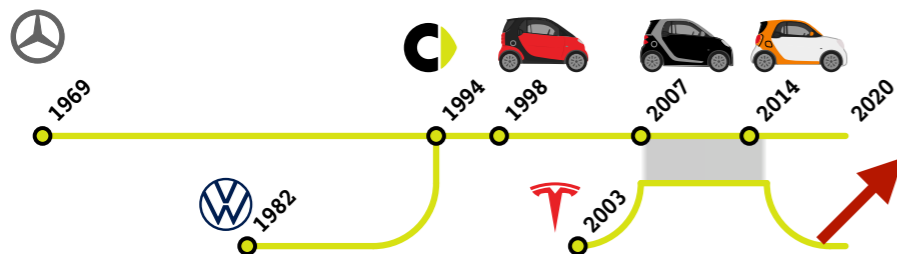



EMOTION

by Moritz Leicht

